

CTX 300

FIXED GAS DETECTOR

- Quick response times
- Pre-calibrated sensor modules
- One man calibration
- Local display (optional)
- Durable in harsh environments



The detection of toxic gases or lack of oxygen requires the installation of detectors satisfying demanding requirements. The CTX 300 range is designed for all safety needs in unclassified areas.

The CTX 300 transmits the relevant data in record time, covering all hazard situations and providing extreme flexibility by way of a wide range of sensors.

Equipped with pre-calibrated sensors, display unit and adjustment devices, the CTX 300 transmitter can be maintained by one person.

FLEXIBILITY AND REDUCED MAINTENANCE

Satisfying your safety requirements means making genuine technical breakthroughs as well as providing clear economic value.

Sensors integrating zero and sensitivity parameters are used so that maintenance is quick and safe.

The principle of the pre-calibrated sensor unit allows maintenance by a single person and significant reduction in costs.

COMPLIANCE WITH STANDARDS

- Compliance with European standards
- EMC in compliance with directives

CERTIFICATIONS



Pending



Pre-calibrated sensor for easier maintenance

The Fixed Gas Detection People

Gas	Reference	Type of sensor	Range (ppm)	Operating temperature	Relative humidity uncondensed
O ₂	WC3002F	Electrochemical	30.00 %	-20 °C to +50 °C	10 % to 95 % RH
	WC3002S		100 %	+5 °C to +40 °C	10 % to 95 % RH
CO	WC30COA	Electrochemical	100	-20 °C to +50 °C	10 % to 95 % RH
	WC30COB		300	-20 °C to +50 °C	10 % to 95 % RH
	WC30COC		1000	-20 °C to +50 °C	10 % to 95 % RH
	WC30COD		1.00 %	-20 °C to +50 °C	10 % to 95 % RH
	WC30COE		10.00 %	-20 °C to +50 °C	10 % to 95 % RH
CO ₂	WC3CO2A	Infrared	1%	-30 °C to +45 °C	5 % to 95 % RH
	WC3CO2B		5%	-30 °C to +45 °C	5 % to 95 % RH
	WC3CO2C		10 %	-30 °C to +45 °C	5 % to 95 % RH
	WC3CO2D		50 %	-30 °C to +45 °C	5 % to 95 % RH
H ₂ S	WC30HSA	Electrochemical	30.00	-20 °C to +50 °C	10 % to 95 % RH
	WC30HSB		100	-20 °C to +50 °C	10 % to 95 % RH
	WC30HSC		1000	-20 °C to +50 °C	10 % to 95 % RH
NO	WC30NOA	Electrochemical	100	-20 °C to +50 °C	10 % to 95 % RH
	WC30NOB		300	-20 °C to +50 °C	10 % to 95 % RH
	WC30NOC		1000	-20 °C to +50 °C	10 % to 95 % RH
NO ₂	WC30N2A	Electrochemical	10.00	-20 °C to +50 °C	10 % to 95 % RH
	WC30N2B		30.00	-20 °C to +50 °C	10 % to 95 % RH
SO ₂	WC30SOA	Electrochemical	10.00	-20 °C to +50 °C	10 % to 95 % RH
	WC30SOB		30.00	-20 °C to +50 °C	10 % to 95 % RH
	WC30SOC		100	-20 °C to +50 °C	10 % to 95 % RH
Cl ₂	WC30CL2	Electrochemical	10.00	-20 °C to +50 °C	10 % to 95 % RH
H ₂	WC30H2A	Electrochemical	2000	-20 °C to +50 °C	10 % to 95 % RH
	WC30H2B		2 %	-20 °C to +50 °C	10 % to 95 % RH
HCl	WC30HLA	Electrochemical	30.00	-20 °C to +50 °C	10 % to 95 % RH
	WC30HLB		100	-20 °C to +50 °C	10 % to 95 % RH
HCN	WC30HNA	Electrochemical	10.00	-20 °C to +50 °C	10 % to 95 % RH
	WC30HNB		30.00	-20 °C to +50 °C	10 % to 95 % RH
NH ₃	WC30NH3		100	-20 °C to +40 °C	10 % to 95 % RH
	WC30NH1		1000	-20 °C to +40 °C	10 % to 95 % RH
	WC3 NH2		5000	-20 °C to +40 °C	10 % to 95 % RH
ETO/PO	WC30OET	Electrochemical	30.00	-20 °C to +50 °C	10 % to 95 % RH
HF	WC30HFA	Electrochemical	10.00	-10 °C to +30 °C	10 % to 95 % RH
O ₃	WC30O3A	Electrochemical	1.00	-20 °C to +50 °C	10 % to 95 % RH
PH ₃	WC30PH3	Electrochemical	1.00	-20 °C to +50 °C	10 % to 95 % RH
ClO ₂	WC30CLO	Electrochemical	3.00	-20 °C to +50 °C	10 % to 95 % RH
COCl ₂	WC30CCL	Electrochemical	3.00	-20 °C to +40 °C	10 % to 95 % RH
Methylene chloride	WC30CLM	Semi-conductor	500	-20 °C to +55 °C	10 % to 95 % RH
Methyl chloride	WC30CLM	Semi-conductor	500	-20 °C to +60 °C	10 % to 95 % RH
Toluene	WC30SOL	Semi-conductor	2000	-20 °C to +50 °C	10 % to 95 % RH
	WC30SOL		500	-20 °C to +50 °C	10 % to 95 % RH
Trichlorethylene	WC30SOL	Semi-conductor	500	-20 °C to +60 °C	10 % to 95 % RH
Xylene	WC30SOL	Semi-conductor	2000	-20 °C to +50 °C	10 % to 95 % RH
Ethanol	WC30SOL	Semi-conductor	5000	-20 °C to +60 °C	10 % to 95 % RH
	WC30SOL		500	-20 °C to +50 °C	10 % to 95 % RH
R12	WC30F22	Semi-conductor	10000	-20 °C to +55 °C	10 % to 95 % RH
R22	WC30F22	Semi-conductor	2000	-20 °C to +55 °C	10 % to 95 % RH
R123	WC30F22	Semi-conductor	2000	-20 °C to +55 °C	10 % to 95 % RH
R134a	WC30F13	Semi-conductor	2000	-20 °C to +55 °C	10 % to 95 % RH
R142b	WC30F13	Semi-conductor	2000	-20 °C to +55 °C	10 % to 95 % RH
R11	WC30F13	Semi-conductor	10000	-20 °C to +55 °C	10 % to 95 % RH
R23	WC30F13	Semi-conductor	10000	-20 °C to +55 °C	10 % to 95 % RH
R141b	WC30F13	Semi-conductor	2000	-20 °C to +55 °C	10 % to 95 % RH
R143a	WC30F13	Semi-conductor	2000	-20 °C to +55 °C	10 % to 95 % RH
R404a	WC30F13	Semi-conductor	2000	-20 °C to +55 °C	10 % to 95 % RH
R507	WC30F13	Semi-conductor	2000	-20 °C to +55 °C	10 % to 95 % RH
R410a	WC30F13	Semi-conductor	1000	-20 °C to +55 °C	10 % to 95 % RH
R32	WC30F13	Semi-conductor	1000	-20 °C to +55 °C	10 % to 95 % RH

BETTER PERFORMANCE, ENHANCED ERGONOMICS

BETTER PERFORMANCE

- Excellent sensitivity and signal stability
- 2 mA signal for maintenance mode
- Signal lower than 1 mA for failure mode

CLEAR READABILITY

- Highly sensitive, lighted display allows local reading
- Effective power-up indication by indicator lights
- Indication of maintenance or fault function

HIGH-LEVEL TECHNOLOGY

- Pre-calibrated sensor avoiding the need to use unstable gases on site for calibration purposes
- Remote sensor unit allowing measurements in even the most inaccessible places
- High-performance semiconductor type detector (detection of freon gas, etc.)

ADVANCED DESIGN

- Highly resistant to environmental elements
- Avoids having to use protective covers

HEAVY-DUTY

- Use of polycarbonate and stainless steel mounting hardware
- Resistant to corrosive agents
- Durable housing

SPECIFICALLY ADAPTED OPTIONS

- Removable filters, interchangeable without opening the housing (which is dust-proof, condensation-proof and water-resistant)
- Splash guard
- Gas collector cone
- Mounting brackets
- Pitot tubes, floats, heating protective device, etc.

Enclosure	Polycarbonate housing
Function	Detector-transmitter
Display	Highly visible backlight display unit (on option)
Indicator lights	In operation: green color (on CTX 300 : 3-wire) Failure / maintenance: yellow color
Link	2 wires – CTX 300 without display unit 3 wires – CTX 300 with display unit
Cable inlet	Between 6 and 11, gland PG9
Power supply	15 to 32 V DC
Power consumption	CTX 300 without display unit: 27 mA
	CTX 300 with display unit: 110 mA
	CTX 300 with display unit, for CO ₂ sensor version, or for solid states sensor versions: 100mA
Operating temperature	-20°C to + 50°C, 4°F to + 122°F
Sealing	IP 66
Weight	520 g
Dimensions	130 x 136 x 69 (l x h x d) in mm
Certification	Safe area only
EMC	Compliance with directives Subject to operation conditions
Impedance	32 ohms max loop for CTX 300 with display unit and for solid states and CO ₂ sensor versions
	128 ohms max loop for CTX 300 without display unit

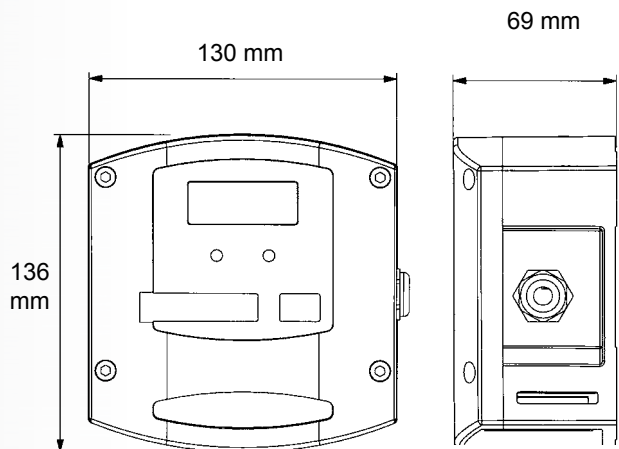

CTX300_Lit_Eng_3May2013