

# Belt Oil Skimmers for All Applications

## Abanaki Corporation's Oil Skimmer Division

Solving oil removal problems for over 30 years world wide, Abanaki's pledge is to work hand in hand with our customers to achieve our shared goal of successful oil/water separation.

Over the years, we have developed rugged, versatile units for many different industries. Our units are simple to operate, reliable, and require very little maintenance. With our wide assortment of belt skimmers and belt types we can efficiently handle hydrocarbons as thick as grease or as light as gasoline. Our different units have removal rates from 1–200 gph.

Give us a call. We have a skilled technical staff on hand to assist you with your application questions, along with any questions you may have about our skimmers. Or look us up at [www.abanaki.com](http://www.abanaki.com) and learn more about our products online.

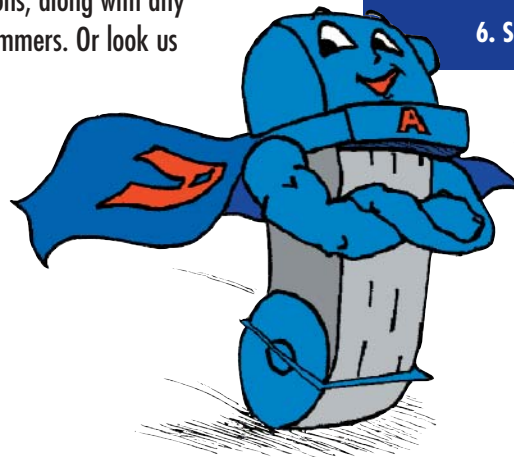

### Other Abanaki Advantages

1. Depending on model selected, skimmer belt material may be user specified—corrosion resistant steel, carbon steel, or one of several specially engineered polymers.
2. The standard material for belt wipers is Nitrile. CRV and Ceramic Hybrid are optional.
3. Abanaki skimmers will perform well in a full range of liquid temperatures with pH levels between 1 and 13.
4. Belt length is specified by the user (length restrictions apply on some units).
5. The standard drive on all units is an electric motor and gear reducer. Other drive types available.
6. Stainless Steel option available on most units.

Abanaki supplies custom designs and turnkey systems to meet specific application needs. Call your sales representative or the factory for specification assistance and a detailed quotation.

**30 Day  
Money Back  
Guarantee**

1-800-358-7546

1-800-358-7546

## Oil Grabber® Advantages

- Single unit elevates and separates oil
- Lifts oil any distance without expensive pumps
- Maintains skimming efficiency with fluctuating fluid levels
- Easy mounting and fast cleaning, with minimal maintenance
- Requires no tank modifications in most applications
- Multiple mounting options for easy installation
- Floor mounting stands available
- Thermostatically controlled heaters available for higher viscosity oils and animal fats
- Optional timer and electrical controls
- Perfect for pre-treatment before filtration or coalescing
- Operates in turbulent liquids (requires some optional equipment)
- Hazardous duty and food grade options available
- Single and three phase motors are standard. Virtually any voltage is available.

### Model 4 Oil Grabber®

- Used when less capacity and smaller size are appropriate
- Oil removal rates up to 20 gph (76 lph)



### Model 82 Oil Grabber®

- Abanaki's most popular model, suitable for most applications
- Oil removal rates up to 40 gph (151 lph)

### Model MB Oil Grabber®

- Can be used in depths as shallow as one foot, or as deep as 100 feet
- Requires no tank modifications in most applications
- Operates in turbulent liquid using optional tail pulley cage and tether assembly
- Easy mounting and fast cleaning, with minimal maintenance



### Grease Grabber®

- Rugged unit for the harshest applications
- Removes up to 160 gph (606 lph) of grease or heavy oils
- Unique hopper design provides efficient discharge of non-flowing greases
- Turnkey systems engineered upon request
- Components for special applications

1-800-358-7546

1-800-358-7546



## PetroXtractor® Well Oil Skimmer

- Allows existing 2" monitoring wells to be used as recovery wells
- Portable—can be moved from well to well
- Maintains skimming efficiency with fluctuating water level
- Removal rates up to 12 gph
- Underground packages with transfer capability
- Explosion proof; pneumatic and vapor tight systems
- Accepts all Abanaki accessories: timers, float switches, oil concentrators
- Removes oils pumps can't handle (Coal tar, Bunker C, etc.)

## Oil Boss®

- All stainless steel construction
- Removal rates up to 16 gph
- Very durable under harsh conditions
- Easy one-step installation
- Includes cord plug, On/Off selector and a pilot light
- Single phase

## The portable Tote-It®

- 36 lb., one-piece portability
- Also for permanent installations with limited access areas
- Oil removal rates up to 12 gph (45 lph)
- Available in lengths up to 10 ft. c-c
- Available with 2" or 4" wide belts
- Different belt materials available
- Easier to use than absorbent pads without the mess

## Duro-Mini®

- Stainless steel construction
- Spring-loaded stabilizer bar
- Available in lengths from 6" to 24"
- Larger single discharge trough
- Designed for parts washers and coolant tanks
- 110v and 220v fan-cooled motors available
- OEM pricing available



**30 Day  
Money Back  
Guarantee**



## Mighty-Mini®

- Stainless steel construction
- 24 hour timer w/15min intervals
- Use in coolant sumps, parts washers, and plating tanks
- Easily hand-carried to the source of the problem
- Oil removal rates up to 2 gph (7.6 lph)
- Designed for liquid level depths from 6" to 24" (15.2 cm to 61.0 cm)
- Belt and tail pulley can fit through a 2" (5.1 cm) bung hole
- Different belt materials available
- 110v and 220v fan-cooled motors available
- Very affordable

## Oil Concentrator®

- Removes residual water in the skimmed oil
- Provides virtually complete oil/water separation
- An optional unit available on all Abanaki oil skimmers
- Uses no electricity, timers, sensors, pumps, or other moving parts
- Optional heater available for high viscosity oils and low temperatures
- Removable sludge screen and drain plug facilitate routine maintenance
- All hardware provided for easy mounting to Abanaki skimmers



# Accessories

Abanaki accessories make it easy to customize your system for quick installation and optimal performance. Listed below are the most commonly requested items. More specialized accessories are available on request — contact the factory.

- Mounting Stands and Adapters
- Controls/Accessories
- Heaters
- Underground Packages

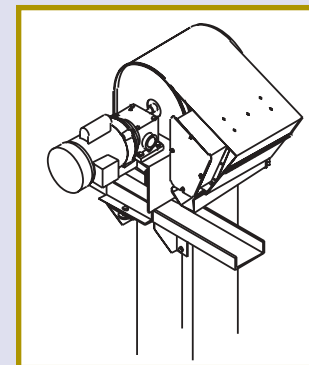
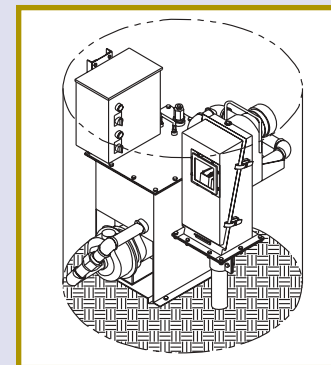
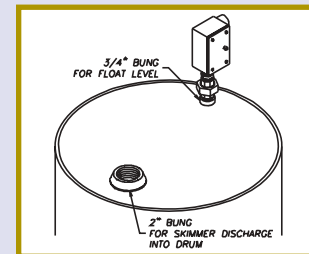
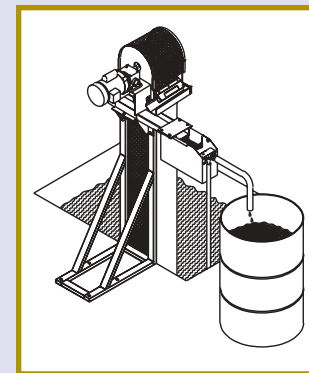

# Belt Skimmers

The Most Effective Way to Remove Oil and Grease From Water

**ABANAKI**

**1-800-358-7546**

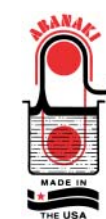

**ABANAKI**  
CORPORATION  
OIL SKIMMER DIVISION  
17387 Munn Road • Chagrin Falls, Ohio 44023  
Ph: (440) 543-7400 • FAX: (440) 543-7404  
800-358-SKIM (7546)  
<http://www.abanaki.com>



**ABANAKI**  
CORPORATION  
OIL SKIMMER DIVISION