

QuickFilter® In-Line Filters

Fast, Economical In-Line Filtration

- Faster, more accurate sampling
- Quick on, quick out, quick off
- CLEAN RINSE pre-rinsed processed

Studies have shown that in-line filtration performed in the field is the best way to assure accurate samples of dissolved metals. QED QuickFilters are the industry leaders in providing the fastest, easiest and most economical in-line filters available. With QED's Clean Rinse process you also get the maximum in sample integrity assurance.

QuickFilters attach directly to sample discharge tubing with no set-up, disassembly, cleaning or tedious changing of clumsy conventional filters and holders.

Rapid sample passage speeds collection even more. Filtration is so fast, samples actually flow, not drip, through the filter. QuickFilters remove solids to 0.45 micron-required prior to metal analysis-minimizing delay and air contact for more consistent, accurate samples.

After sampling just detach the filter and its on to the next well. There's no need for laborious decontamination between samples.

QuickFilters are the original disposable in-line filters. As the developers, QED leads the way in making field filtration easier and more economical.

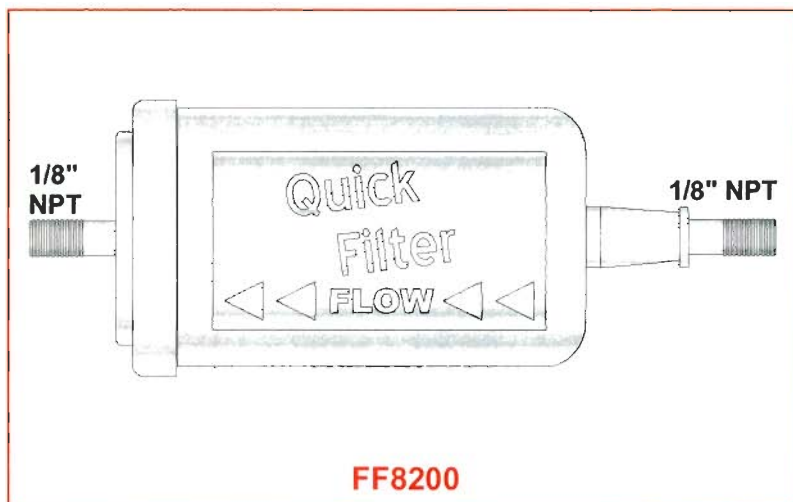

QuickFilters are available in standard and high capacity models. Each filter contains a membrane type filter for absolute particle cutoff at 0.45 microns, in a leak-proof polypropylene housing. QuickFilters are rated for 60 P.S.I. maximum pressure.

For maximum sample purity, QuickFilters are manufactured with no adhesives, sealants, potting compounds, or other foreign materials.

By using QED's model FF8500 sample vessel any ground water sampling program can share the advantages of QuickFilters, no matter what sampling device is used. The transfer vessel is much faster than traditional vacuum flasks. A sample can be filtered in under 5 minutes with no prefiltration step.

SPECIFICATIONS:

Model No.	Capacity	Area	Filter Material	Pore Size	Maximum Pressure
FF8100	Standard	30 cm ²	Polyethersulfone	0.45 microns	60 P.S.I.
FF8101	Standard	30 cm ²	Polypro	1.00 microns	60 P.S.I.
FF8200	High	609 cm ²	Polyethersulfone	0.45 microns	60 P.S.I.
FF8201	High	770 cm ²	Polypro	1.00 microns	60 P.S.I.
FF8205	High	770 cm ²	Polypro	5.00 microns	60 P.S.I.

ACCESSORIES:(Ordered separately)-**Model No. FF8500**- Sample transfer vessel with hand pump, **35780**- Transfer vessel stand, **8810**-Connector for 1/2" O.D. tubing, **8815**- Connector for 3/8" O.D. tubing, **8820**- Connector for 1/4" O.D. tubing, **8825**- Connector for 3/4" O.D. connector.

TRANSFER VESSEL SPECIFICATIONS:

Model No.	Volume	Height	O.D.	Weight	Cap Material	Reservoir Material	Maximum Pressure
FF8500	1100 ml	12.63"	5.25"	3 lbs.	Polypro	Styrene-Acrylonitrile	125 P.S.I.

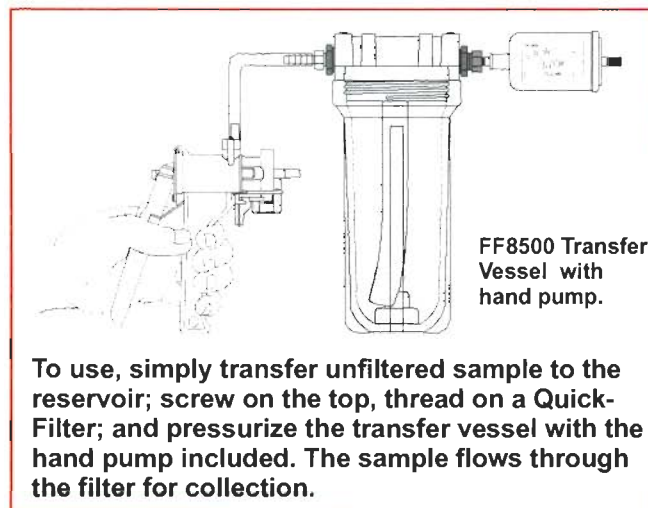

Clean Environment Brasil
 Rua Raggio Nóbrega, 129 •Campinas, SP 13025-310
 fone: (19) 3255-6301 • fax: (19) 3294-2701
www.clean.com.br